

Technical description winLIFE, Fatigue analysis solution

winLIFE (Life Information using Finite Elements) can be used with or without finite elements for fatigue life prediction. The Nominal Stress Method, the Local Stress Method and the Local Strain Approach are implemented. Different modifications of the S-N-curve are supported. Generators exist for component S-N-curves and for material life curves according to the UML. Powerful tools to analyse and correct measured load time histories are included. There are three modules:

- winLIFE BASIC
- winLIFE MULTIAXIAL
- winLIFE GEARWHEELS AND BEARINGS

The basic module can only solve proportional problems, but the multiaxial module can also solve non-proportional and non-synchronous problems. It is possible to connect to finite element programs, because FEMAP-Format is used, nearly all other FE-programs which run on Windows OS can be used.

Introduction

Light weight construction is becoming more and more important and the construction is often limited by fatigue life. winLIFE provides the well known and proved methods such as the Nominal Stress Method and the Local Strain Approach in a user friendly interface to relieve the user from complex mathematical operations.

The application of Finite Element Analysis is commonly used and in many cases indisputable. As a result winLIFE is designed to be connected to finite element programs running under Windows NT. To avoid any interface problems, it writes and reads files in the FEMAP-format and an access to nearly all FE-programs is possible.

Most of the common theories are implemented, so that in the hands of an experienced user is a powerful tool for fatigue life prediction.

winLIFE is an open program, the data structure is documented to enable the user to access it for his own use or to implement additional features.

Here the theory is described and two examples are shown for fatigue calculation.

1) Proportional cases (winLIFE BASIC)

In the case of proportional loading there are many possible common solutions derived from the Nominal Stress Method or the Local Strain Approach, which are supported by winLIFE.

The different types of stresses, which are used for fatigue calculation and the most important parameters are shown in figure 1, where a notched plate is loaded by a pull force.

1.1) Implementation of the Nominal Stress Method in winLIFE

The traditional way of calculating fatigue life is using the Nominal Stress Method (fig. 1). This procedure has been proved in numerous experimental results and it has been shown that

when used by an experienced engineer, this method leads to satisfactory results. This method is the foundation of many construction rules.

Win LIFE uses component S-N-curves for fatigue life prediction.

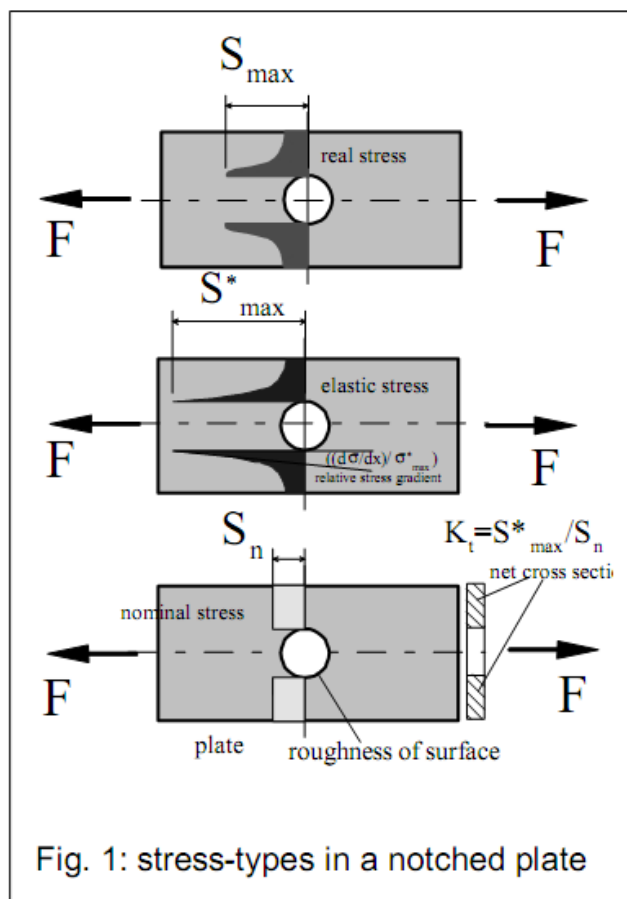

If the user knows the S-N data, he can enter them into , if he does not, these curves can be generated using the following data according to [1]

static material data

- R_m ,
- $R_{p0,2}$

component data

- K_t ,
- material treatment,
- roughness of the surface,
- related stress gradient

Many different modifications of the S-N-curves (fig. 2) and consideration of the mean stress (fig. 3,4) is possible.

According to the mean stress a transformation of S-N-curve (fig. 3) or stress transformation (fig. 4) is possible.

The user can use the slope in the ranges one to four according to existing standards [3,4] or he can also enter his own data. Finally the damage accumulation is according to Miner's law.

The flow diagram in figure 5 shows how to use the Nominal Stress Method. It is possible to use local stresses in a similar way to the Nominal Stress Method. This procedure is also supported by and gains in importance in multiaxial calculations.

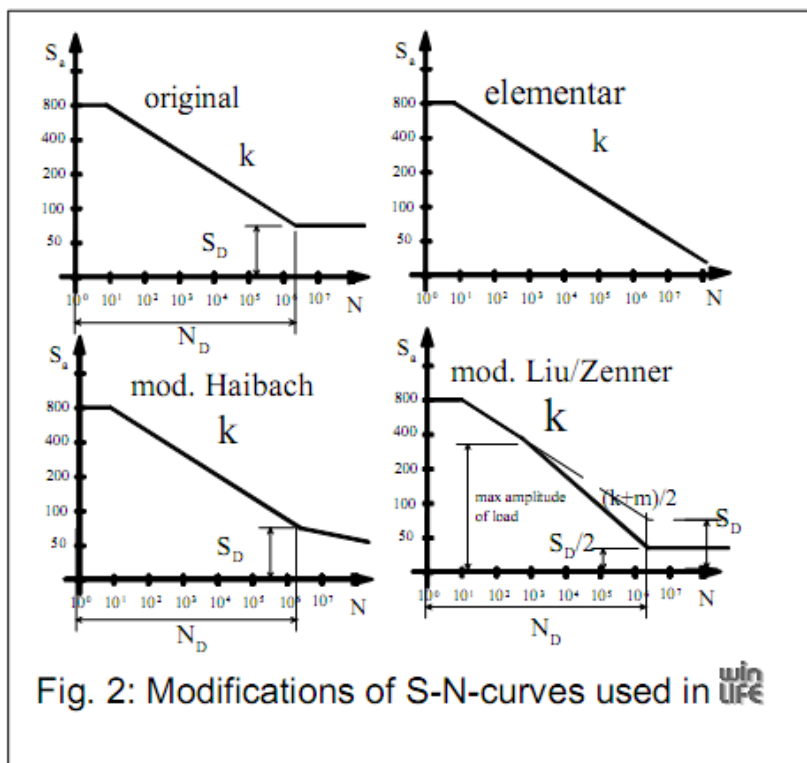

Fig. 2: Modifications of S-N-curves used in win LIFE

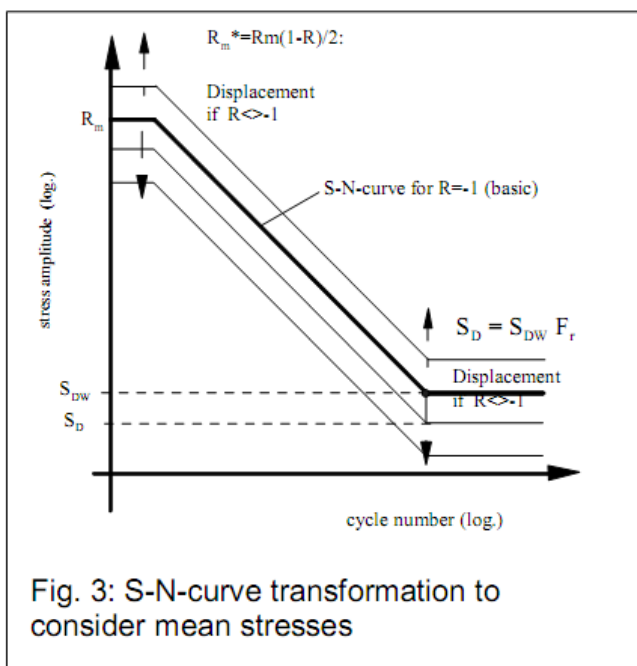

Fig. 3: S-N-curve transformation to consider mean stresses

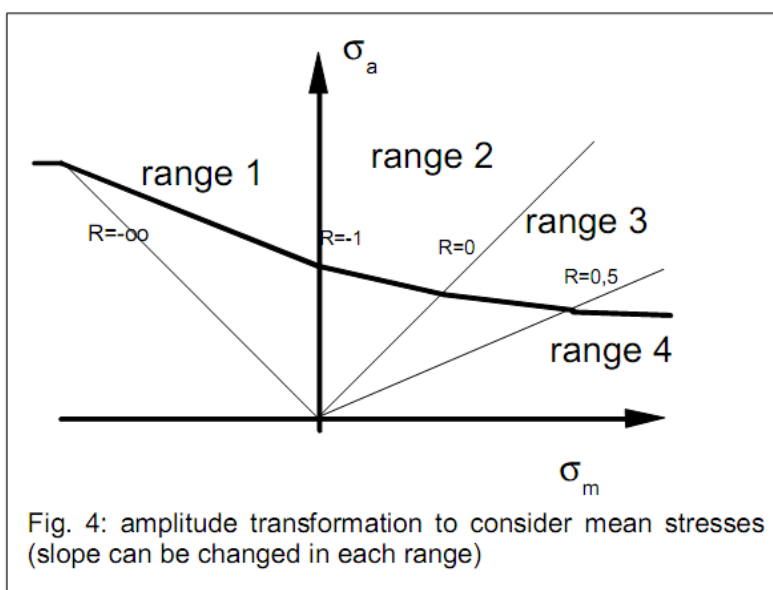

Fig. 4: amplitude transformation to consider mean stresses (slope can be changed in each range)

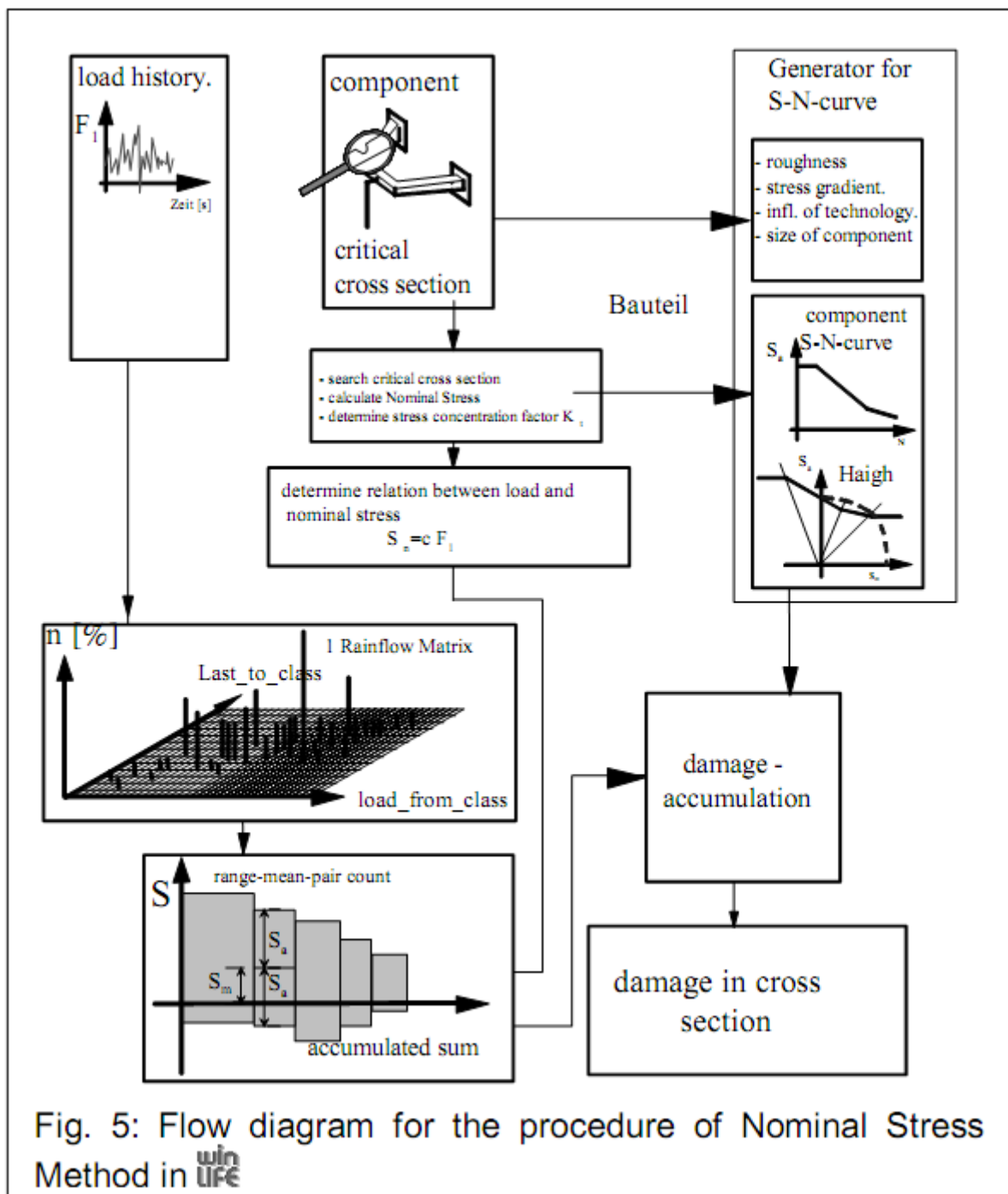

Fig. 5: Flow diagram for the procedure of Nominal Stress Method in **winLIFE**

1.2) Implementation of the Local Strain Approach in winLIFE

The Local Strain Approach takes into account the real local stress and strain just as if a local specimen in a component were to be subjected to a load. (fig.6). The relation between the turning points of the load strain path and the stress strain path enables the analysis of the load time history by rainflow count. It also enables the construction from the rainflow matrix and the cyclic material properties to the local stress strain path (fig. 7). The rainflow count algorithm includes the correction according to Clormann/Seeger [7] and has been extended to consider hysteresis and classes.

winLIFE uses the common equations according to Ramberg Osgood to

describe the cyclic properties and the Masing behaviour.

$$\epsilon_a = \frac{S_a}{E} + \left(\frac{S_a}{K'} \right)^{1/n'}$$

and

$$\Delta \epsilon = \frac{\Delta S}{E} + 2 \left(\frac{\Delta S}{2K'} \right)^{1/n'}$$

winLIFE carries out fatigue analysis based on elastic stresses.

The transformation from the elastic stress to the real stress is done using Neuber's rule. The appropriate modifications can be selected (fig. 8). The damage is calculated according to the damage parameter of Smith, Watson and Topper.

$$P_{SWT} = \sqrt{(S_a + S_m) \epsilon_a E}$$

Further damage parameters are being worked on. Additionally an endurance limit can be used. The only limitation of the length of a time history is the disk space.

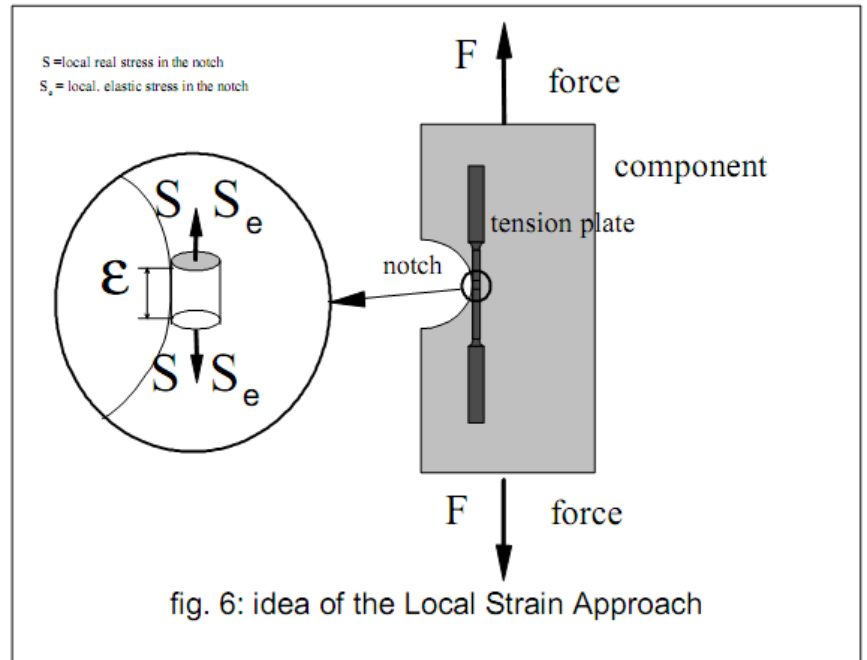

Figures 9, 10 and 11 show a typical load history, the resulting rainflow-matrix and the calculated stress-strain-path.

For more in-depth interests, winLIFE supports the interactive construction of the stress strain path only with the help of the material memory. So the user can move along the loading in both time directions step by step .

If the Local Strain Approach is used in conjunction with a finite element analysis, the calculation will be carried out as shown in the flow diagram (fig. 12) . If winLIFE is used without finite elements, the user has to enter the elastic stress. In this way a nominal stress combined with K_t or an elastic stress from a traditional mechanical analysis can be the basis of the fatigue calculation.

winLIFE includes a material data bank and a generator for life curves based on static material data as is proposed in the NML (Uniform Material Law) [9].

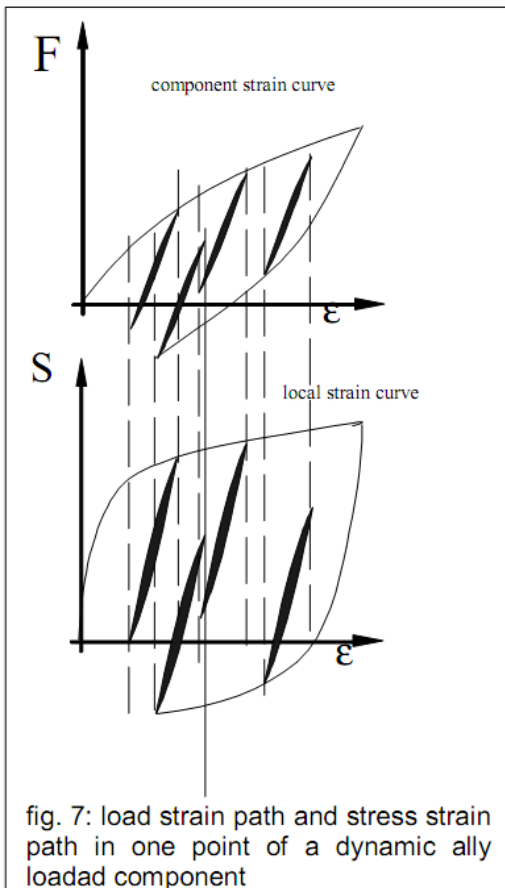

fig. 7: load strain path and stress strain path in one point of a dynamic ally loadad component

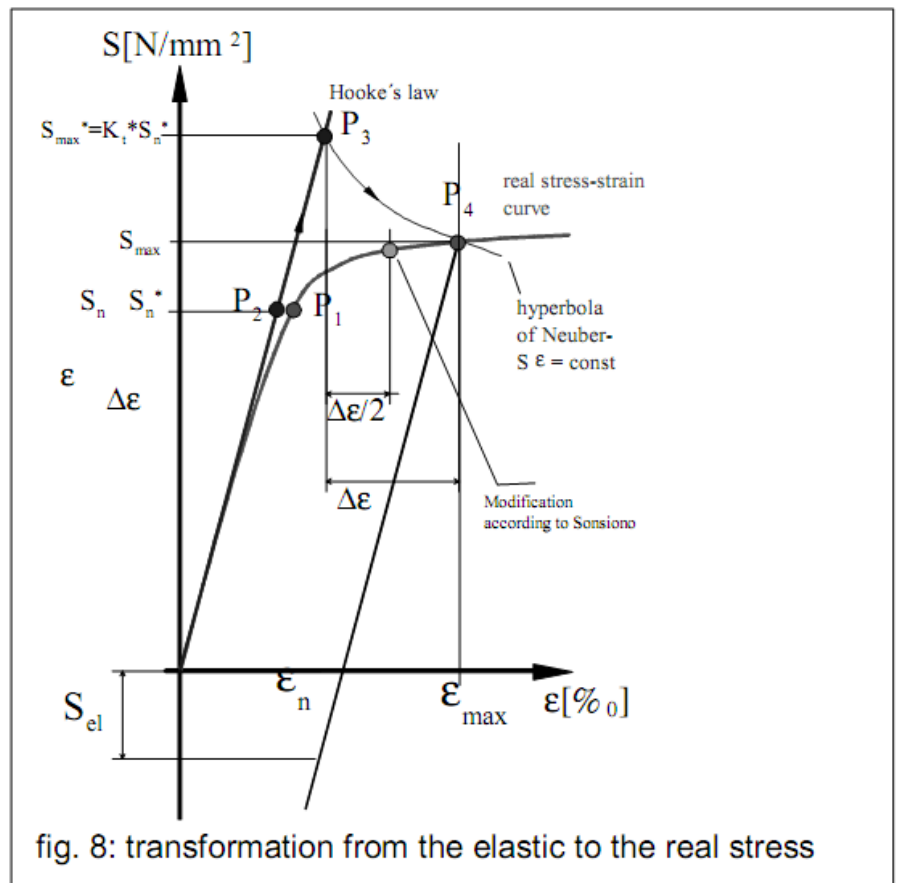

fig. 8: transformation from the elastic to the real stress

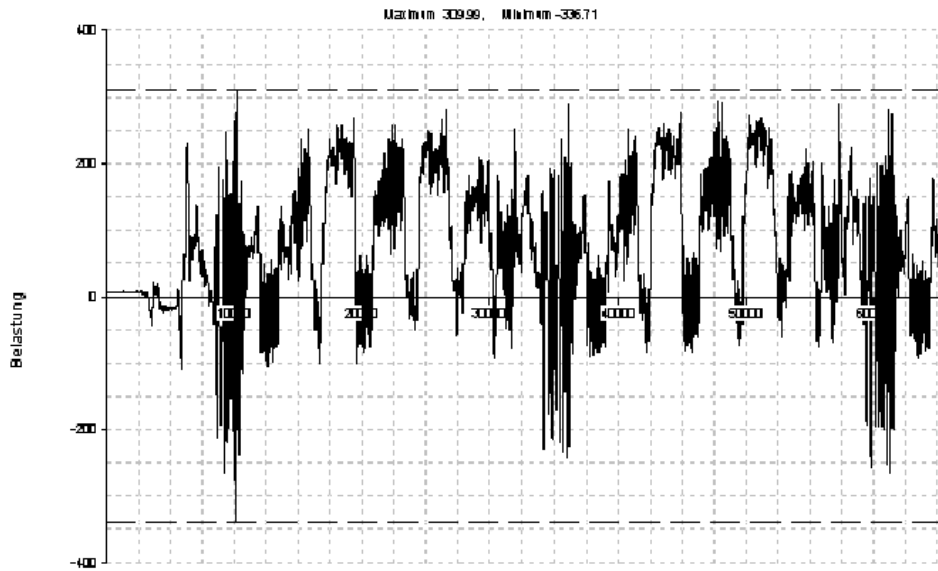

Fig. 9: Load time history of the forces in a heavy truck stabilisator (hardly any limit in length)

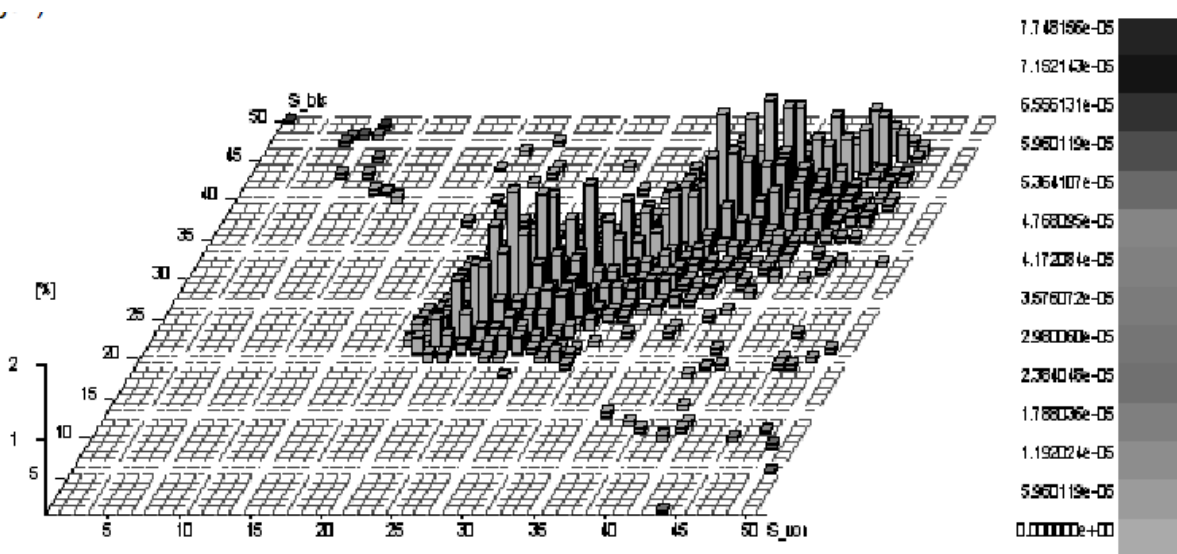

Fig. 10: rainflow matrix of the loading from fig. 9.

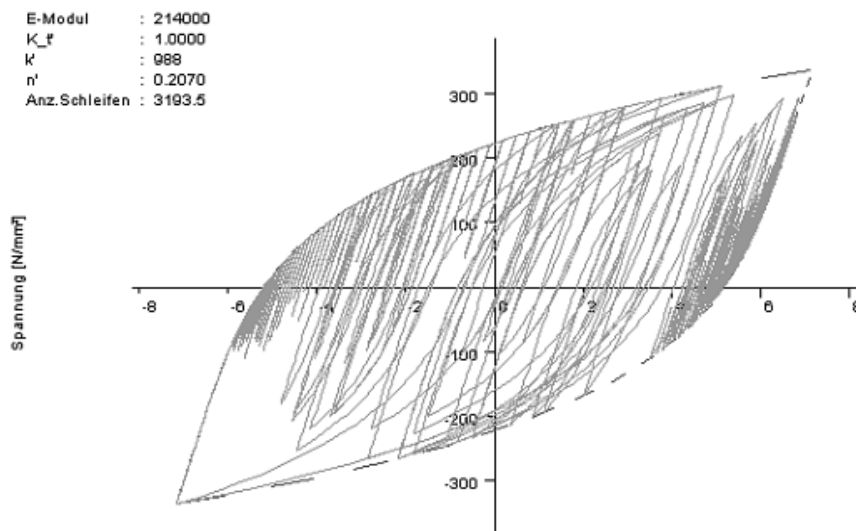

Fig. 11: Stress-strain path constructed from the rainflow-matrix and the cyclic properties of the material

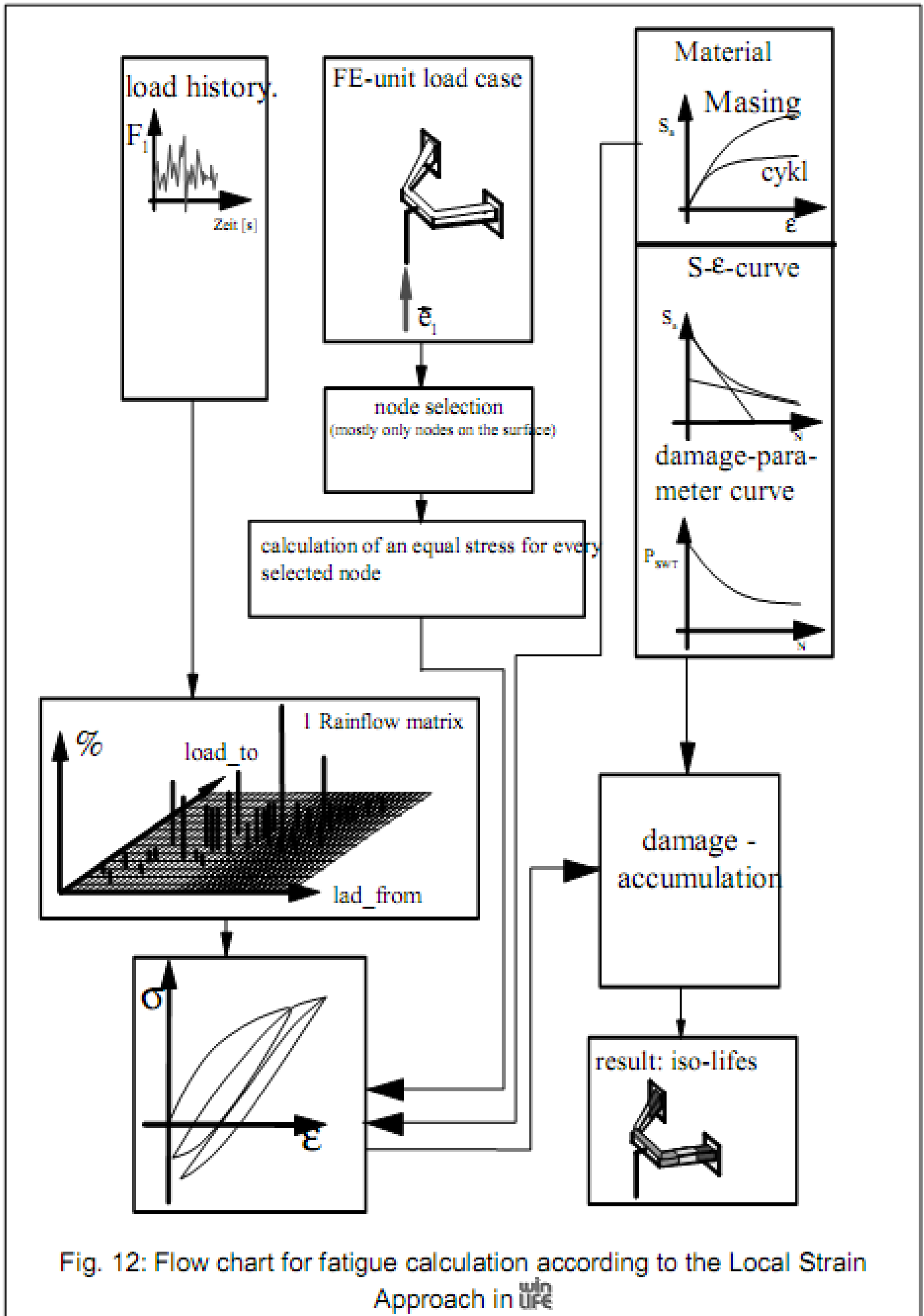

Fig. 12: Flow chart for fatigue calculation according to the Local Strain Approach in win LIFE

2) Changing directions of principal stresses (winLIFE MULTIAXIAL)

It is much more complex to calculate a fatigue analysis when the principal stress directions are changing than it is when they are constant. It is therefore important to establish first of all, whether the problem is really non proportional.

The table in fig. 14 shows three cases and the parameters which help to identify whether a problem is non proportional or not. The angle ϕ and the ratio σ_1/σ_2 of the stresses are useful parameters which are calculated for all time steps. winLIFE uses these as shown in figures 15 and 16.

In some cases a problem of changing stress directions can be simplified by a proportional calculation. This results in a greatly beneficial reduction of calculation time. Two different cases in red and black colour are shown in the figures.

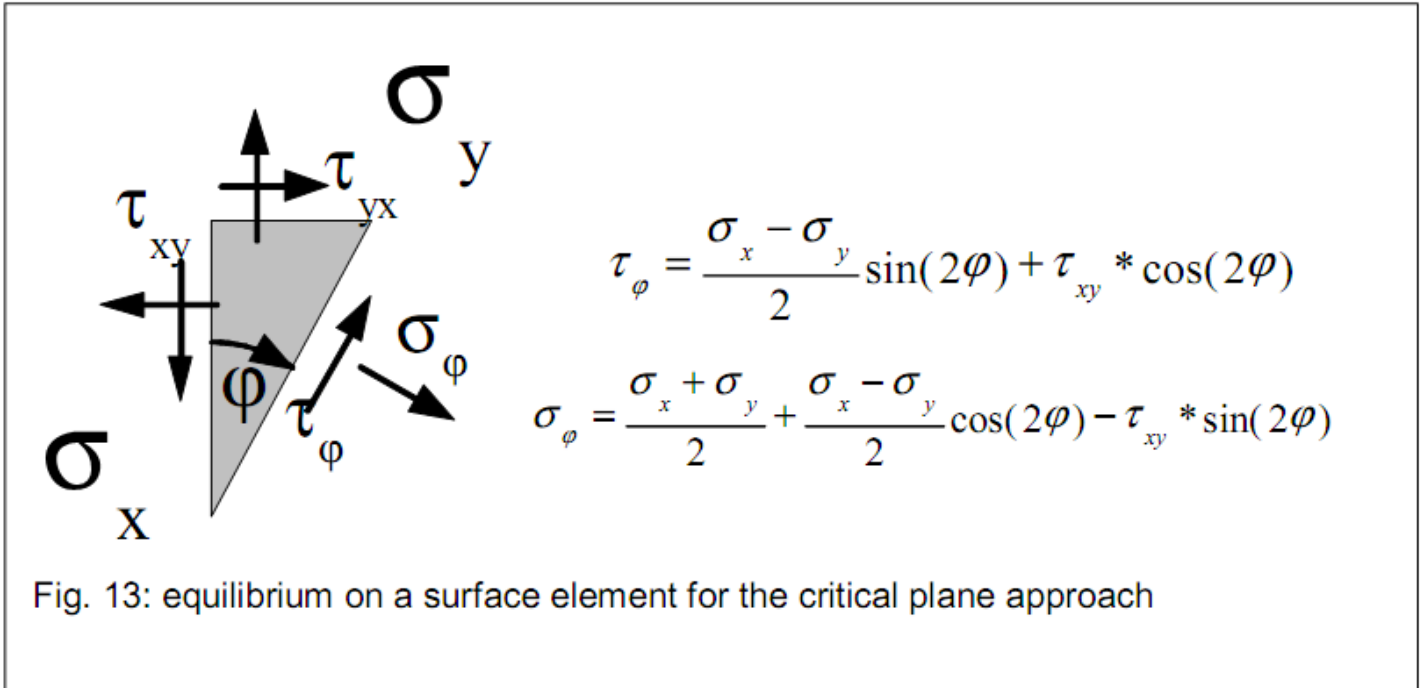

case	ϕ	σ_1	σ_2	$\frac{\sigma_2}{\sigma_1}$	mohr`s circle	structure
uniaxial <small>direction of principal stress and direction of loading are identical</small>	=0	variable	=0	=0	 <small>in every time step mohr`s circle touches zero point</small>	
biaxial <small>proportional loading several loading are acting proportionally in different directions</small>	const	variabel	variabel	const $-1 < \frac{\sigma_2}{\sigma_1} < +1$ and $< > 0$	 <small>for every time step mohr`s circle is geometrical similar</small>	
multiaxial <small>non-proportional loading several loading are acting independently in different directions</small>	variable	variable	variable	variable	 <small>geometry of mohr`s circle may change for every in any way</small>	

figure 14: classification of the possible cases

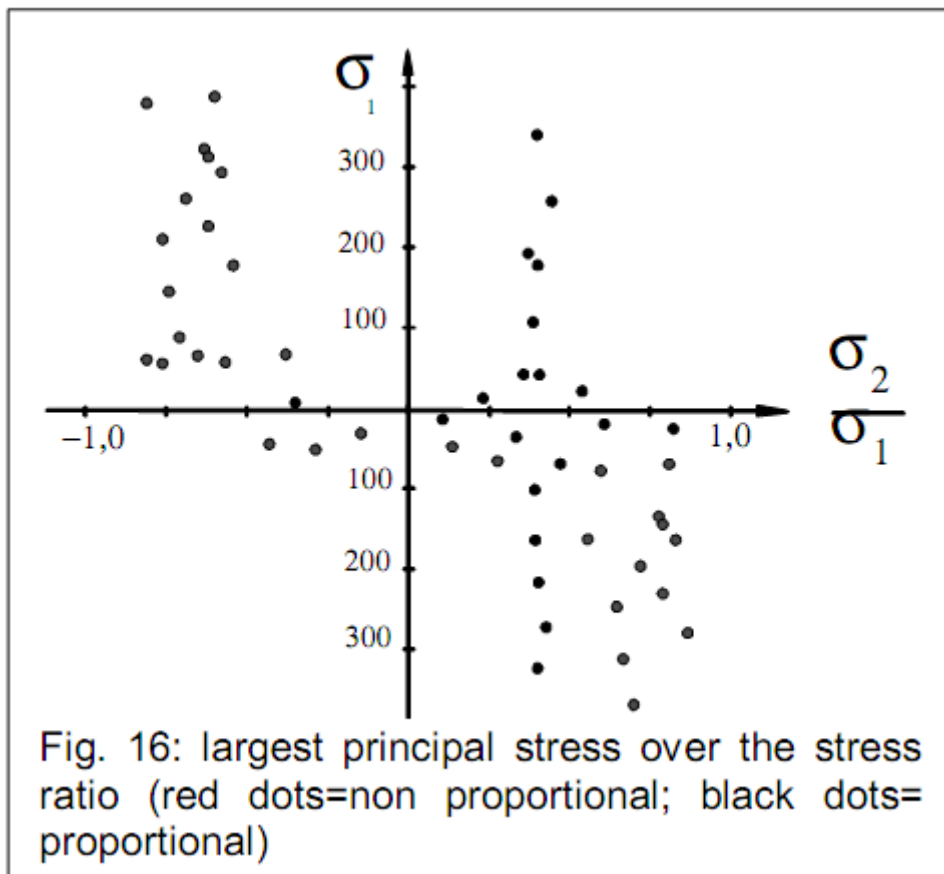
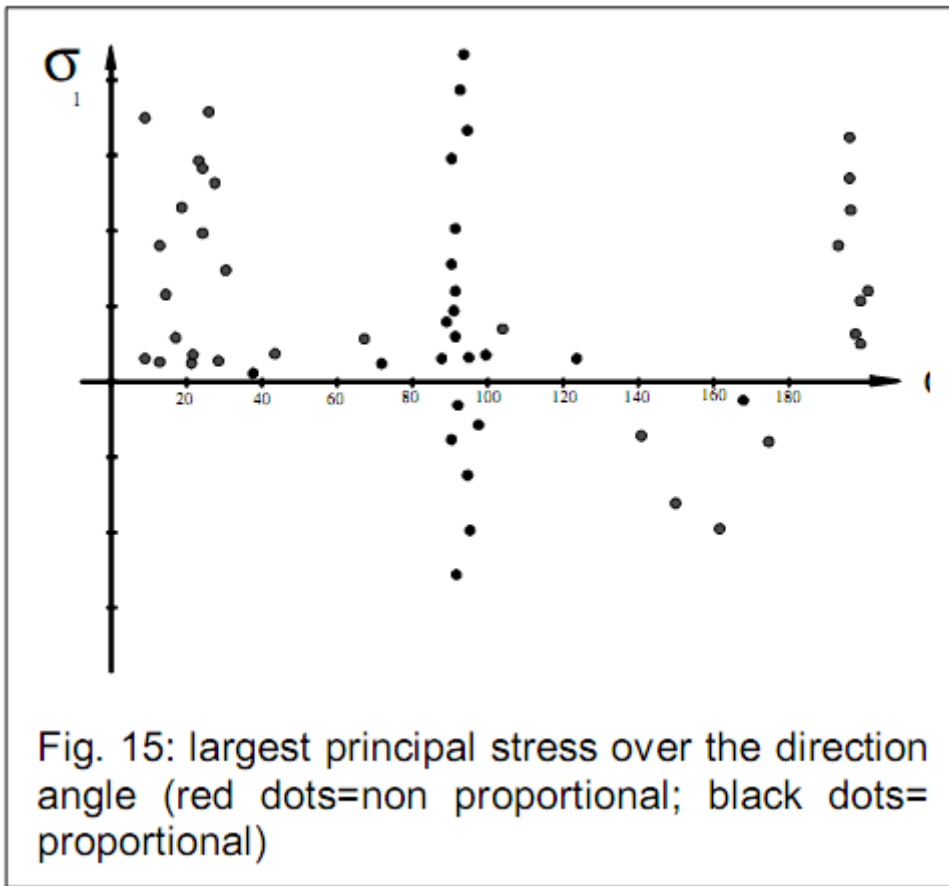

2.1) Case 1: When the loadings are already available

If loadings are given, winLIFE performs a fatigue calculation in combination with a finite element analysis if dealing with a non proportional case. This procedure is shown in the flow chart. There are usually a lot of non synchronous loadings acting on a structure.

Because in most cases damage starts from the surface, fatigue life calculation can be simplified by analysing only the surface. This means, that only plane stresses have to be considered. Figure 13 shows a triangle in the surface and the stresses in the x-,y and φ -directions. Depending on the angle φ , the stresses τ and σ change.

The stresses in each plane are calculated for the total load history and an equivalent stress is also calculated for each plane based on the following formula:

$$\sigma_v = \text{MAX}(c * \text{sign}(\sigma_\varphi), d * \text{sign}(\tau_\varphi)) * \sqrt{a * \sigma_\varphi^2 + b * \left(\frac{\sigma_w}{\tau_w}\right)^2 * \tau_\varphi^2}$$

Depending on the material properties the factor a or b can be set to 0. A rainflow count of this time history in each plane is carried out and a damage calculation is done. A S-N-curve is used which has to be modified by local properties such as the related stress gradient and the surface property.

The flow chart of a non proportional fatigue calculation is shown in figure 19.

Calculation time can be a problem for long load time histories and in such cases the following two steps should be carried out when doing a fatigue calculation:

- a precheck estimate of all nodes on the surface to find the possible critical points,
- a final calculation just for the nodes to be considered which were derived from the precheck

During the precheck analysis a calculation is done:

- only for the common turning points of the load time histories (fig. 17)
- using a hysteresis between 10 and 20% to reduce the number of turning points (fig. 18).

Both these simplifications of the precheck estimate lead to a remarkable reduction of calculation time.

The nodes are sorted according to damage and the node number is written into a file. If the final calculation step is carried out for only a limited number of preselected nodes without these simplifications, the calculation times are largely acceptable.

The reduction in calculation time is proportional to the reduced number of nodes. More than 90% of the nodes are usually not of interest and are not calculated.

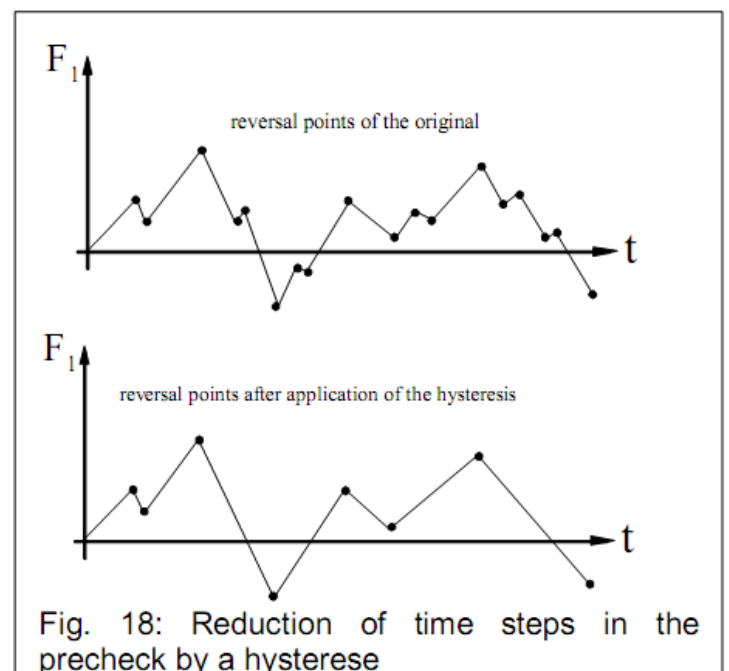
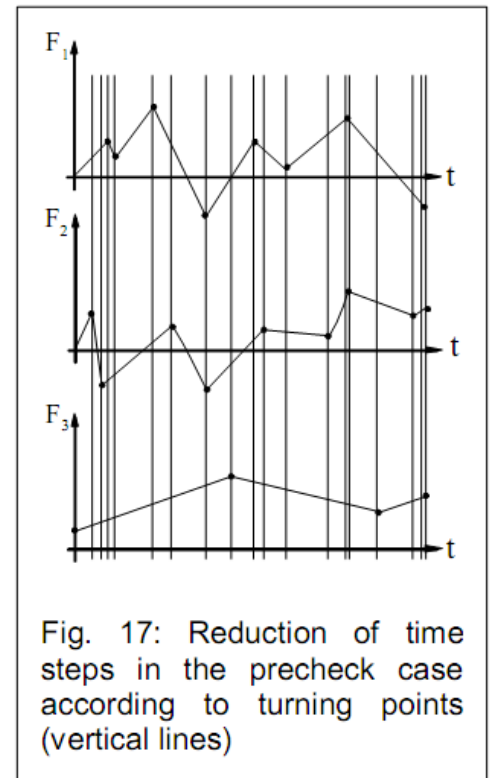

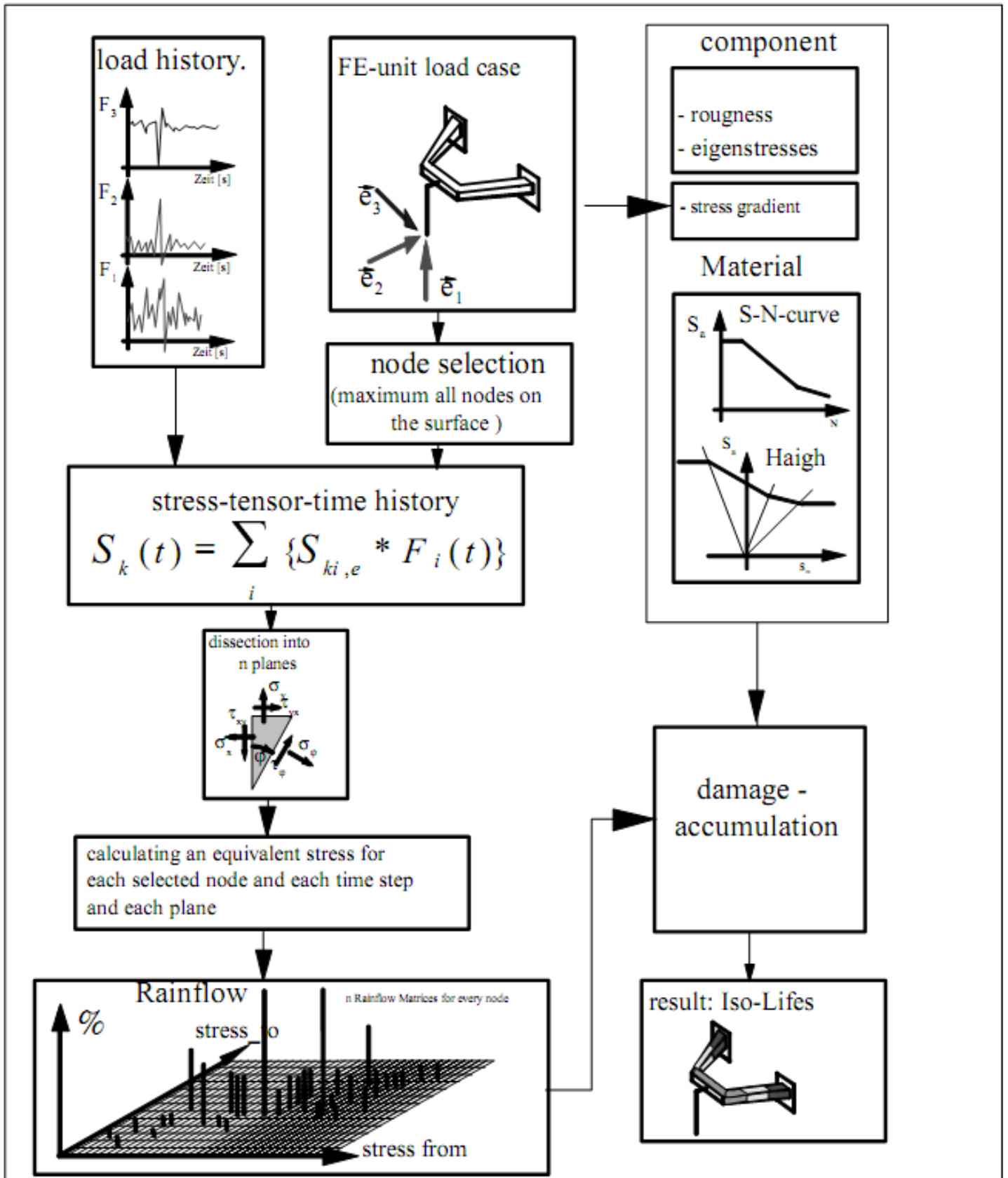

Fig. 19: flow diagram for the procedure of multiaxial fatigue analysis using win LIFE

2.2) Case 2: When measured strains (gain rosette) are available

When measured strains are available, no finite element analysis is used and only the locus of measurement can be calculated. Mostly these data are got from a strain rosette. A model of Mros'z is used to make a prediction similar to the Local Strain Approach.

2.3) Data handling

winLIFE includes tools for graphically interactive data handling and data correction. Time histories can be corrected simply. Offsets can be changed, spikes removed, the drift corrected. It is possible to generate all types of spectra. The rainflow matrix itself can be changed interactively. Data from other programs such as measurement systems or Matlab/Simulink can easily be imported.

3) Gearwheel and bearing

Fatigue calculation of gearwheels and bearings is similar to that of the Nominal Stress Method. A user who is familiar with the basic module will soon be able to work with it. supports common calculation methods based on DIN or FVA standards. These standards deal with life curves for different material and design parameters of wheels.

The modifications of the life curves used in the basic module (fig. 2) are also used for gear wheels.

The loading is described in a different way: typically the torque time percentage (fig. 20) is used and is converted into a spectrum of torque over total number of revolutions.

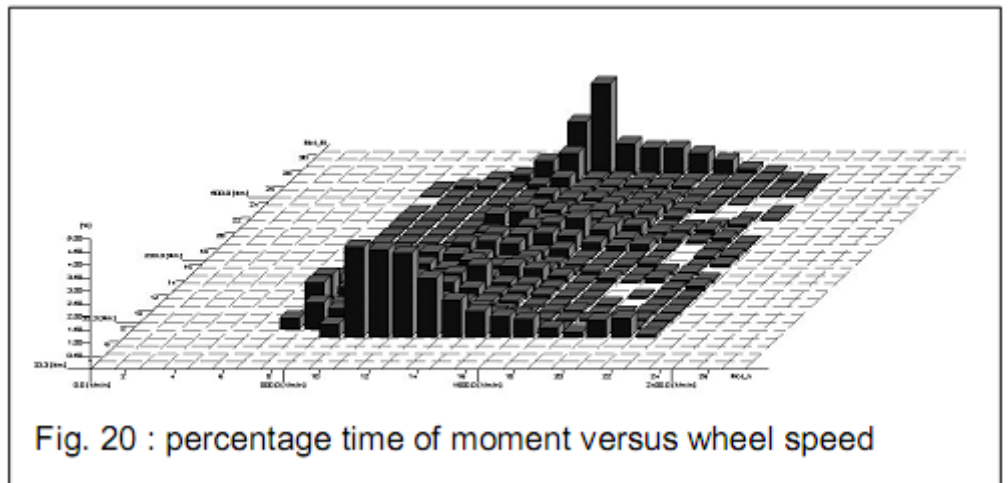

Fig. 20 : percentage time of moment versus wheel speed

3.1) Gear tooth base fatigue

Gear tooth base fatigue occurs due to dynamic bending of the gear tooth base, which can result in a primary crack and finally to a tear in the tooth, depending on the roughness of the surface, the stress and the notch factor (figure 22).

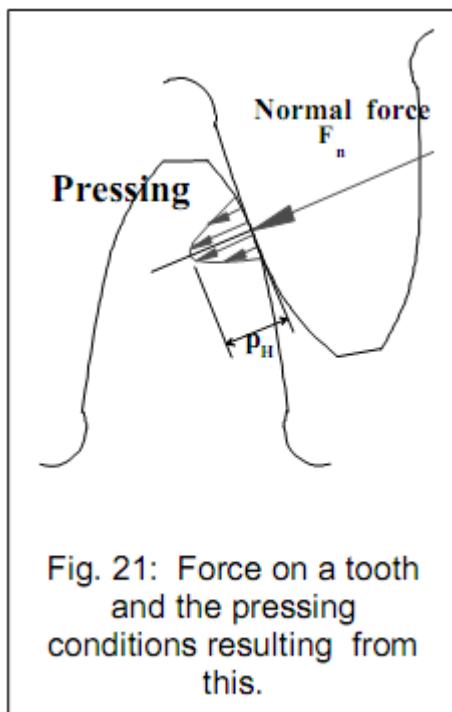

Fig. 21: Force on a tooth and the pressing conditions resulting from this.

3.2) Tooth flank fatigue (pittings)

When the force of the tooth shifts to the tooth flank, it causes Hertz' Pressing which can lead to material fatigue in the form of pittings (Fig. 21). Fatigue life can also be described with S-N life curves according to FVA.

3.3) Bearings

The fatigue life calculation of bearings is also included. This is carried out based on information from the manufacturer and is available in catalogues.

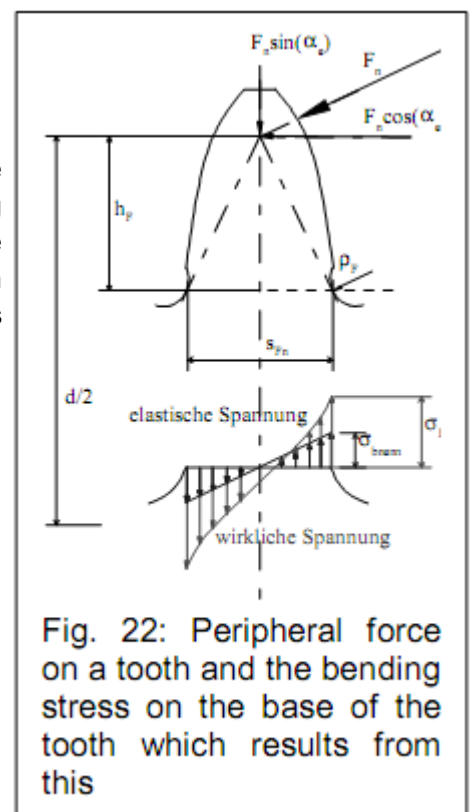

Fig. 22: Peripheral force on a tooth and the bending stress on the base of the tooth which results from this

4) Examples

4.1) Retarder wheel for a hydrodynamic retarder brake

A Voith retarder shaft with a gearwheel which is used in heavy trucks is calculated. The torque was measured under different conditions for nearly 30 hours.

The shaft is pre-stressed by a pipe, and there is a helical gear on the right of the picture (fig. 23). To calculate the stresses caused by the rotation of the shaft, 4 load cases with a rotational angle of 0, 90, 180 and 270 degrees were created (fig. 24). The load-cases are worked through in this order and they are transformed by the measured torques to actual stresses. The number of cycles results from the shaft speed. The calculation was done with winLIFE MULTIAXIAL.

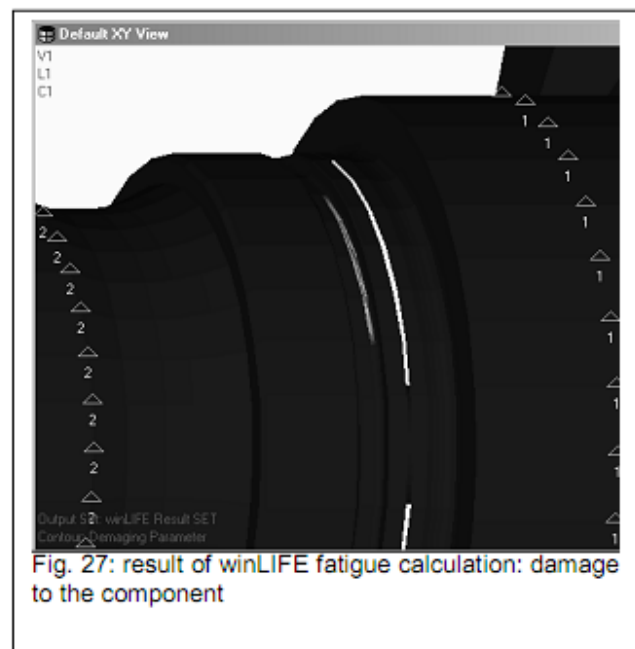
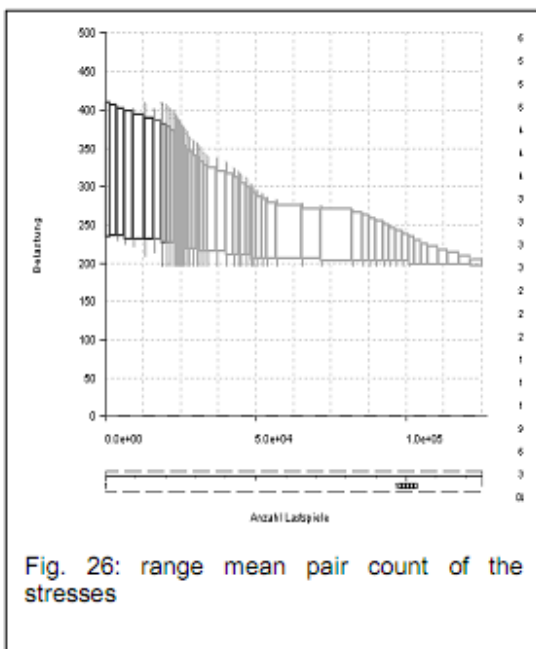
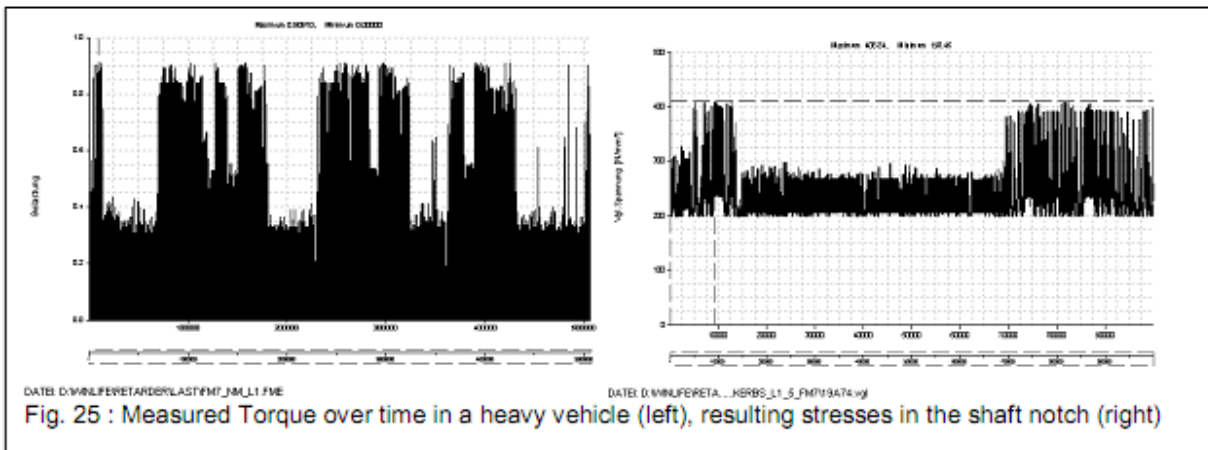
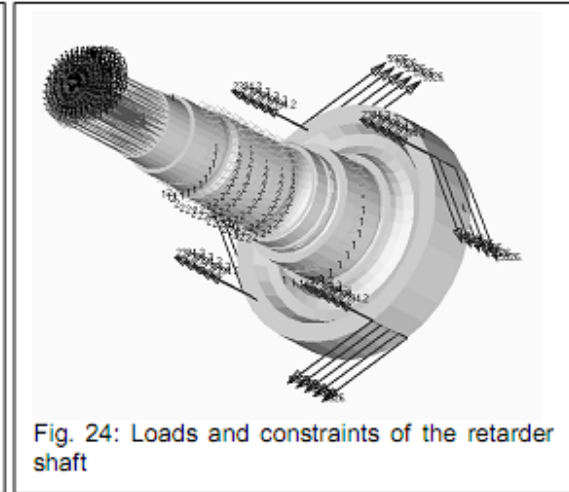
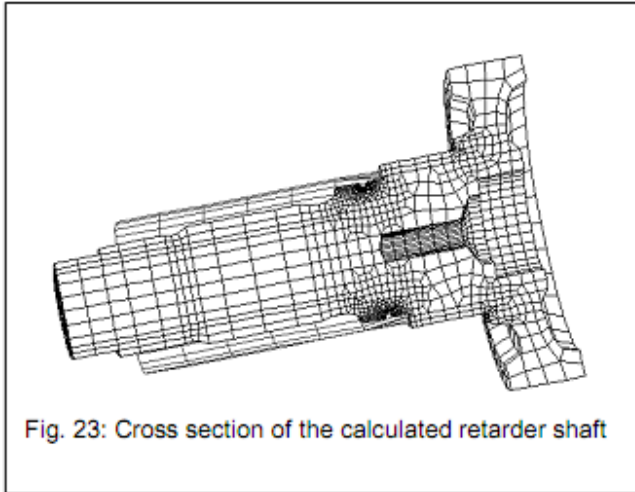

4.2) Stabilisation beam for heavy trucks

A stabilisation beam is used in a heavy truck vehicle suspension system. It is loaded lengthways by measured forces (fig. 29). Additionally a constant pre-stress is caused by an indented pressed rubber element into the bearing on the left of the picture (fig. 29). The rubber element was substituted by boundary conditions and resulting forces which act on the beam element bearing (fig. 28). Fig. 29 shows half of the FE-model. Because of the pre-stress, the fatigue calculation was carried out with winLIFE MULTIAXIAL.

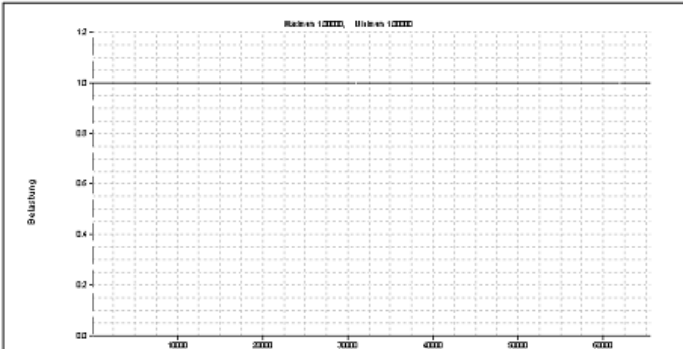

Fig. 28: result of rubber pressing in the bearing over time (load case 1).

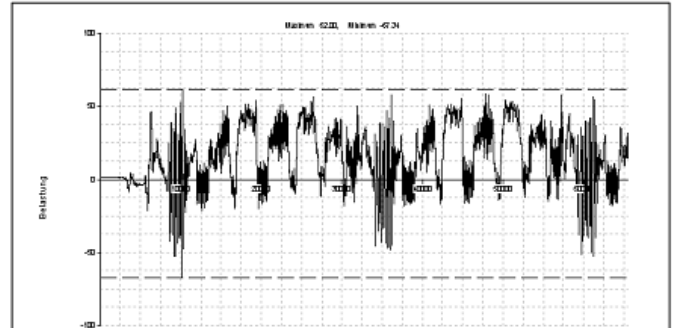

Fig. 29: Acting load over the time from measurement (load case 2).



Fig. 30: result of fatigue calculation of the stabilisation beam of a heavy truck vehicle

5) References

- [1] Hück, Thraier, Schütz: Berechnung von Wöhlerlinien für Bauteile aus Stahl, Stahlguß und Grauguß, Synthetische Wöhlerlinien, Verein deutscher Eisenhüttenleute Arbeitsgemeinschaft Betriebsfestigkeit, Mai 1981
- [2] Gudehus, Zenner: Leitfaden für eine Betriebsfestigkeitsrechnung, Empfehlung zur Lebensdauerabschätzung von Maschinebauteilen. 3. Auflage, ISBN 3-514-00445-5, Verlag Stahleisen, Düsseldorf.
- [3] Zenner H. und Liu J.: Vorschlag zur Verbesserung der Lebensdauerabschätzung nach dem Nennspannungskonzept, Konstruktion 44 (1992) Seite 9-17
- [4] Haibach, E., Berger, C., Hänel, B., Wirthgen, G., Zenner, H., Seeger, T.: Rechnerischer Festigkeitsnachweis für Maschinenbauteile, Heft Nr. 183-1, 1994, Forschungskuratorium Maschinenbau, Lyonerstr. 18, Frankfurt/M.
- [5] Störzel, K.; Sonsino C.M.: Verfahren zur Lebensdauerabschätzung auf der Basis von Rainflow-Matrizen örtlicher Dehnungen; Fraunhofer - Institut für Betriebsfestigkeit (LBF), Darmstadt, LBF-Nr. 7662 (1994), unveröffentlichter Eigenforschungsbericht.
- [6] Smith, K. N., Watson, P., Topper, T. H.: A Stress-Strain Function for the Fatigue of Metals. Journal of Materials, 5 (4), S. 767 - 768, 1970
- [7] Chlormann, U. H., Seeger, T.: Rainflow-HCM - Ein Zählverfahren für Betriebsfestigkeitsnachweise auf werkstoffmechanischer Grundlage. Stahlbau, 55(3), S. 65 - 71, 1986
- [8] Muralidharan, U; Manson, S.S.: A Modified Universal Slopes Equation for Estimation of Fatigue Characteristics of Metals. Journal of Engineering Materials and Technology, 110:55-58, 1988
- [9] Bäuml A.; Seeger, T.: Materials Data for Cyclic Loading, supplement 1, Elsevier Science Publishers B.V.1987, ISBN 0-444-88603 6

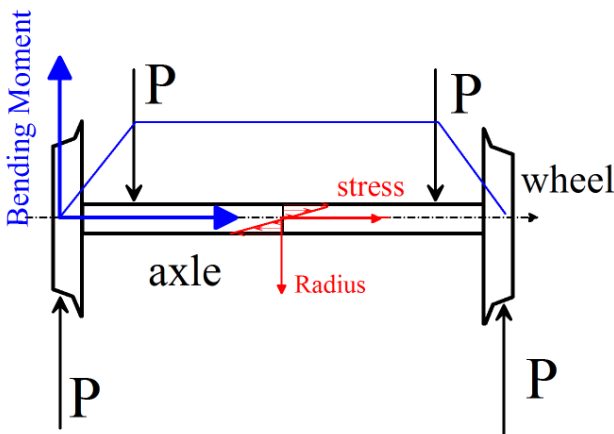

This technical description is based on a paper from:

Prof. Dr.-Ing. Günter Willmerding

Dipl.-Ing.(FH) Jakob Häckh

SteinbeisTransfer Center, New Technologies in Traffic Engineering, Ulm, Germany

Dipl.-Ing. K. Schnödewind

MSC.Software Partner Solutions GmbH, Marburg, Germany

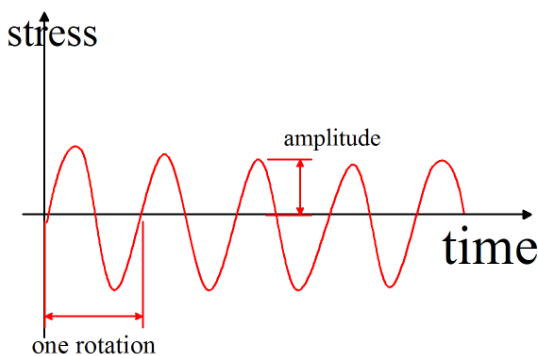

winLIFE is a Steinbeis GmbH & Co. product

<http://www.stz-verkehr.de>



COSMOS ITALIA Srl
Via Giovanni Lonati, 8
26100 Cremona - Italy -

Tel. +39 0372 436072
Fax +39 0372 36049
info@cosmositalia.it

www.cosmositalia.it